

TOP VIEW

All components - 316 Stainless steel

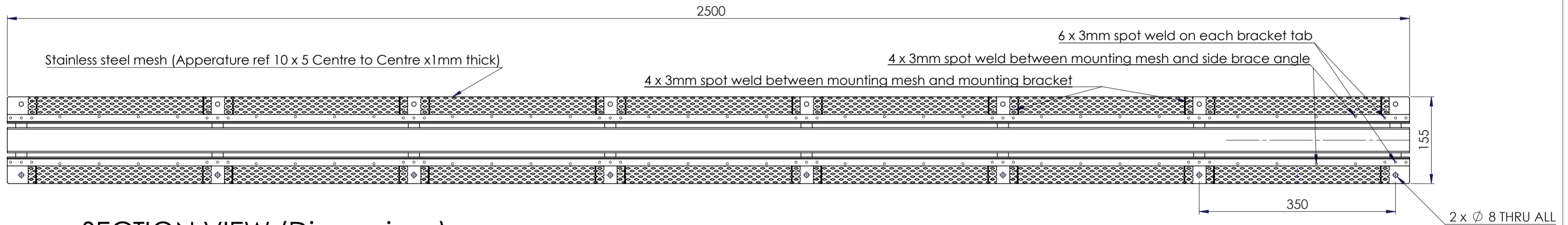

SECTION VIEW (Dimensions)

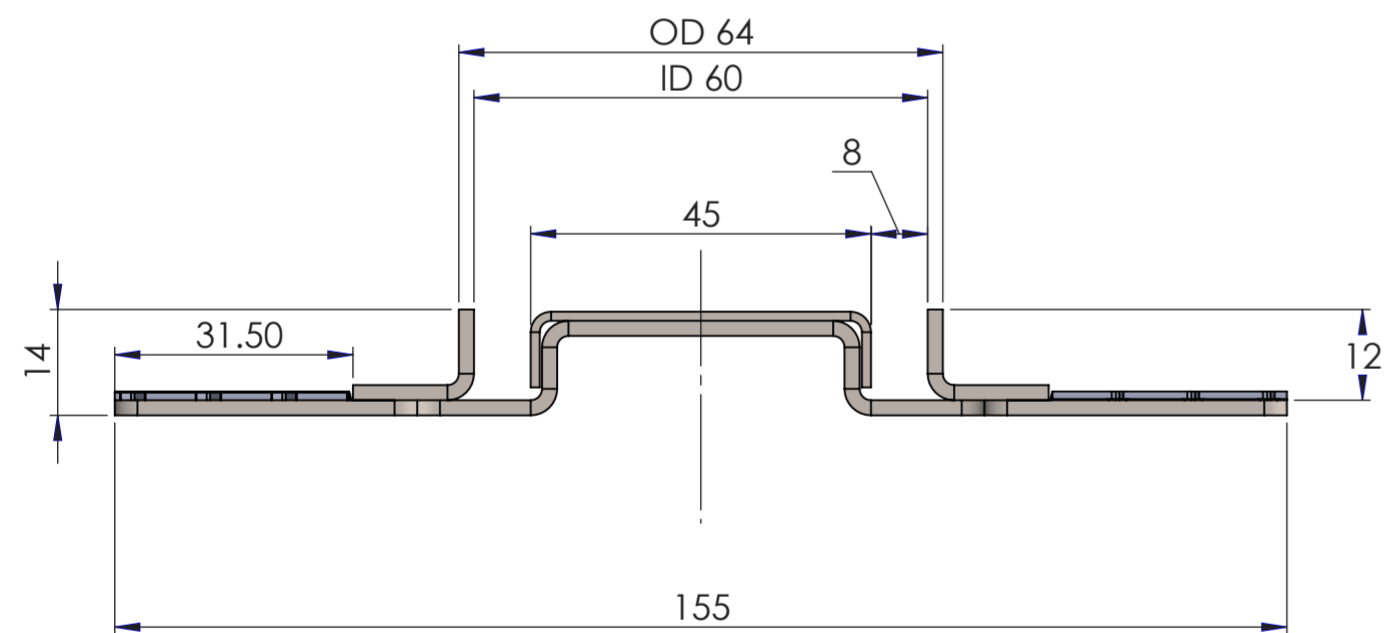

Overall height from ground 14 mm

SECTION VIEW (Details and finish)

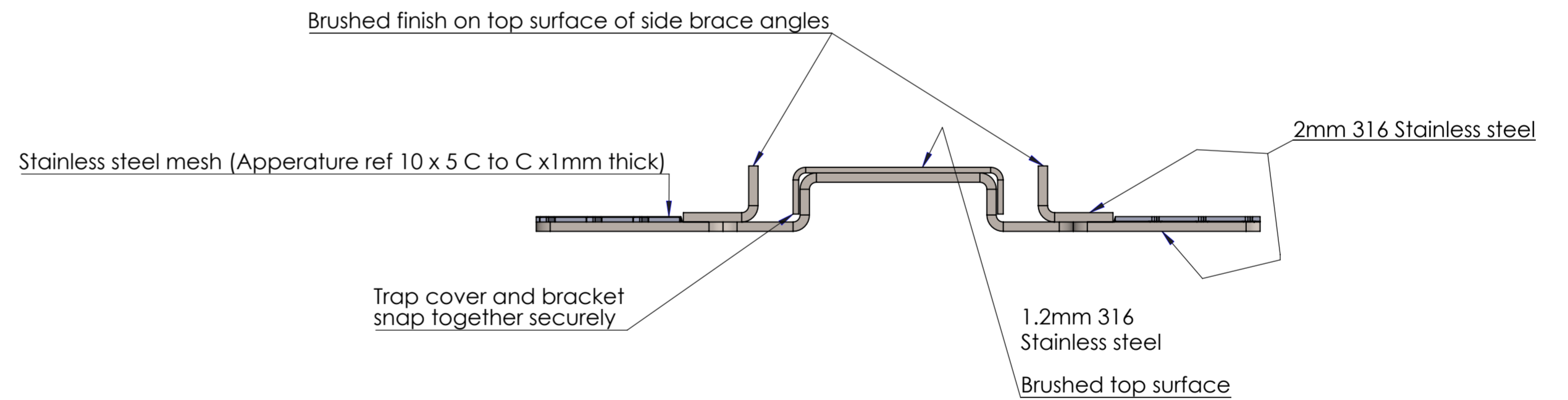

Notes:
Unless Otherwise Specified: All dimensions are in millimeters.

MATERIAL:
SS 316

DRAWN BY
Bradley Wallace

DATE
30-11-2017

FINISH:
Brushed 240 Grid

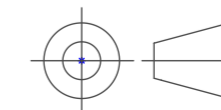

Project:
Alessia Rainwater Channel

Title:
Section Views

MASS/grams: -

DRG: 2 of 3

SCALE: 1:5